

Power Distribution Schematics in Wiring Systems

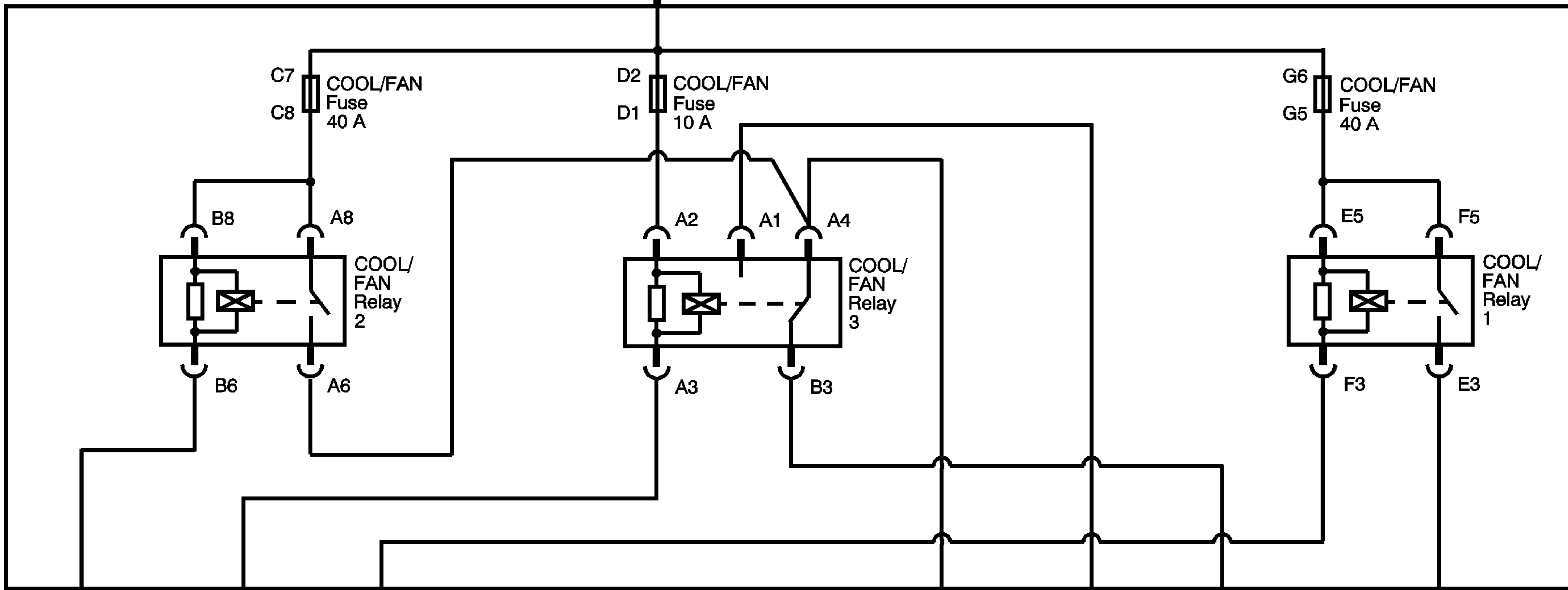
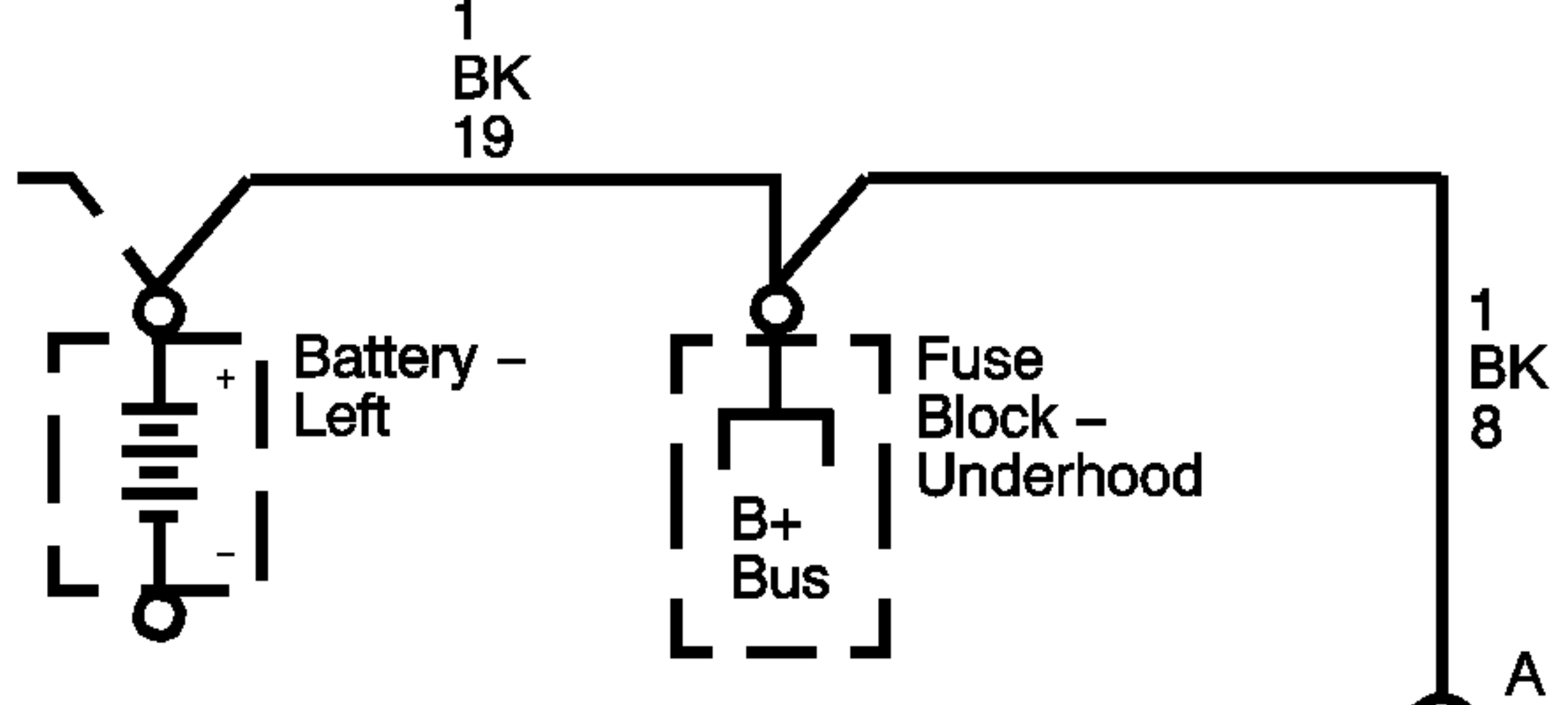

Fuse Block - Underhood - Cooling Fan

Applied the 2005 Silverado electric fan cooling scheme to a 2002 Silverado. Used the same PCM pinouts as the 2005 Silverado. Note that the C2-33 pin in 1999-2002 Silverado is designed for the PCM control of the HVAC Recirculation Door. Removed this wiring and reprogrammed PCM for the new function.

OEM harness from 2006 Suburban was used for the installation.

