

CONN ID
C1=68 L-GY
C2=68 BK
C3=32 RD
C4=32 L-GN
C5=2 GY
C6=2 L-GN
C7=2 BK
C8-NOT USED
C9=2 NA

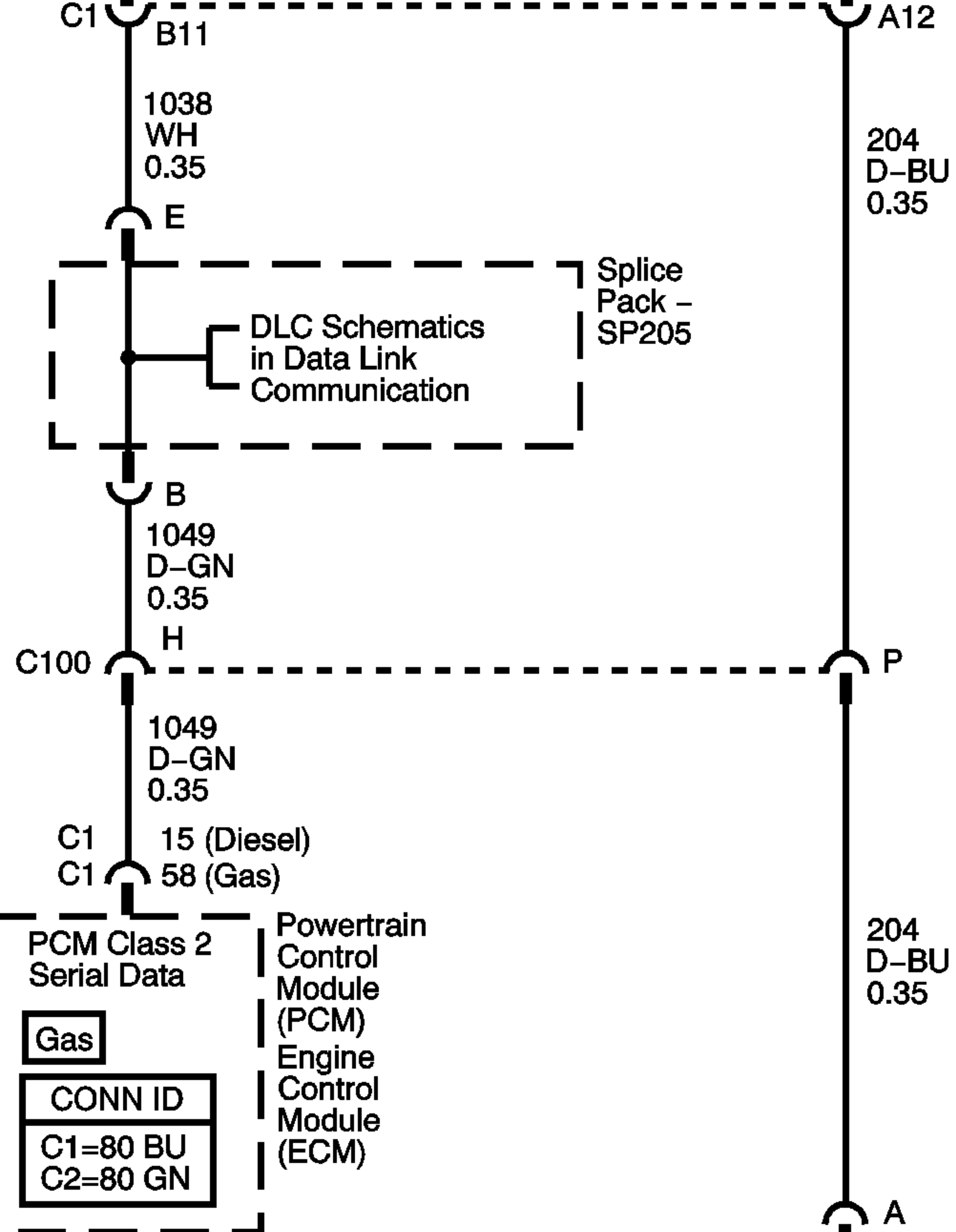
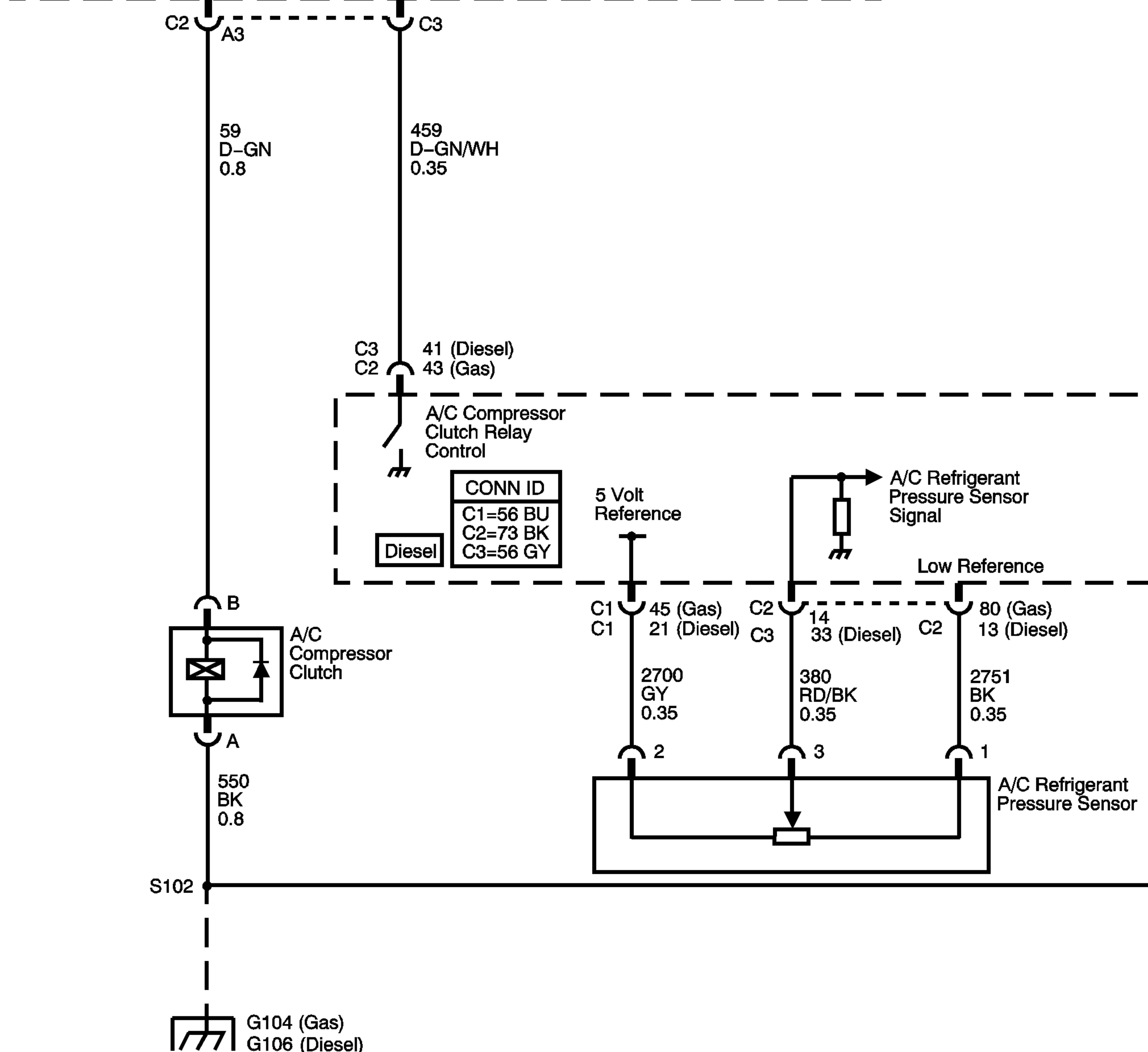
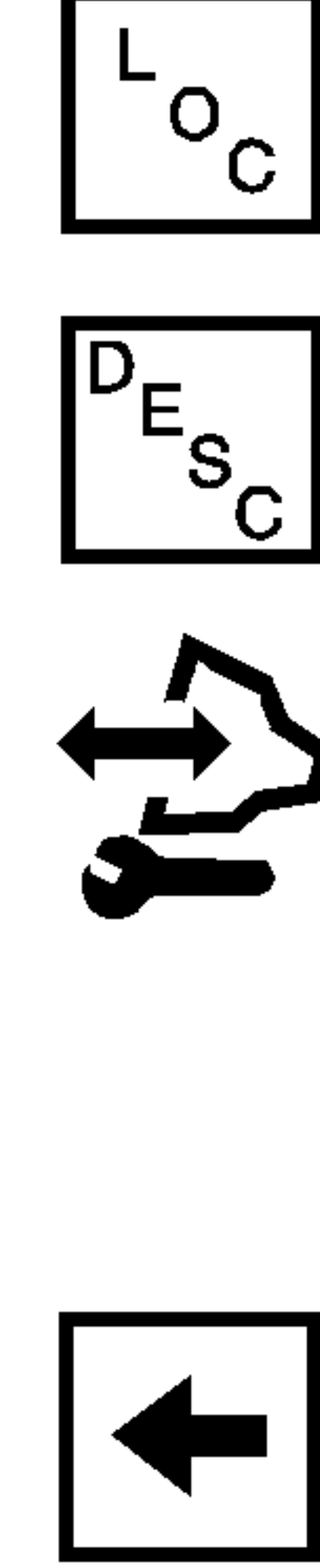
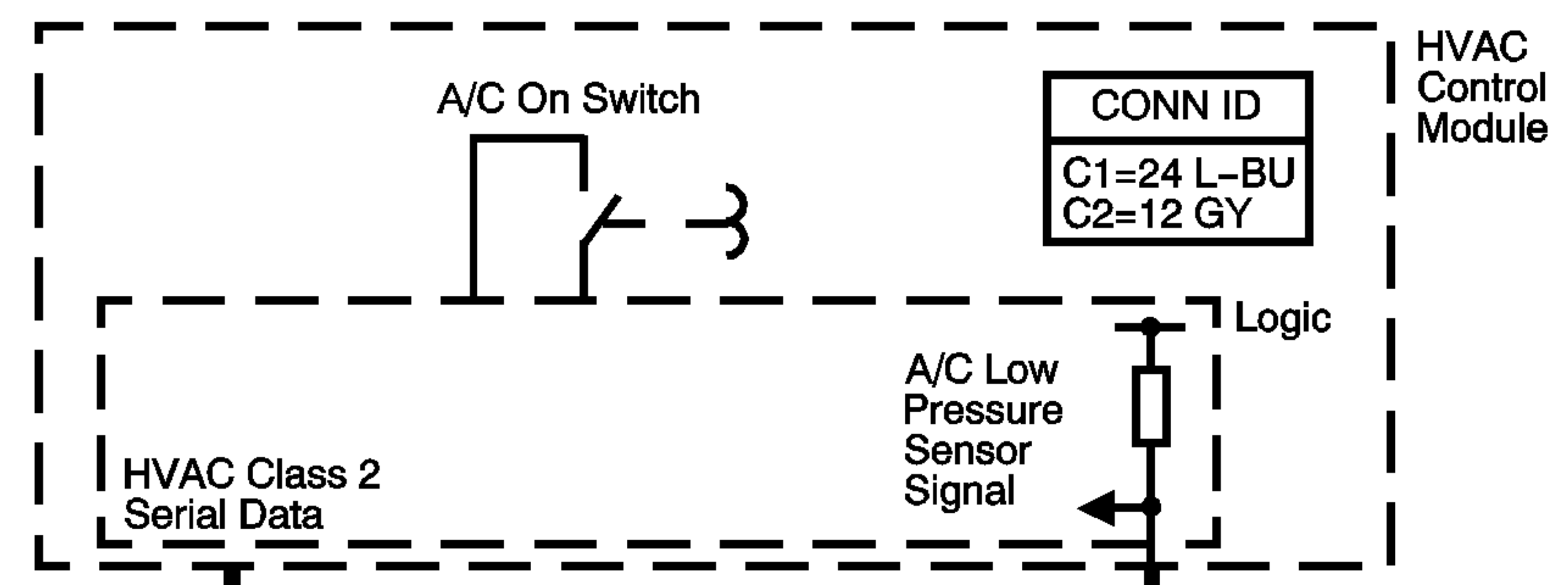

Included for reference. 2005 Silverado sent A/C activation signal over Class 2 Data Bus and HVAC unit controlled when to cycle clutch, thus why the low pressure switch wires to the HVAC unit. PCM still controls fan clutch activation.